

*Israeli Air Force*

# F-16C Barak Block 30/40

Photo: Shay Finkelman ©



117 Squadron



110 Squadron



101 Squadron



115 Squadron

# IsraDecal

THE COMPLETE SCALE MODELLING EXPERIENCE

GOING GREEN

DOWNLOAD INSTRUCTIONS



Also available from our website:  
[www.isradecal.com/instructions](http://www.isradecal.com/instructions)

**IsraDecal**   
STUDIO

[www.isradecal.com](http://www.isradecal.com)

The stencils on IAF F-16s, in general, are in English and quite similar to other worldwide F-16s, with some exceptions.

The original stencils painted by Lockheed Martin are included in the markings for FS 36118 Gunship Grey and FS 32356 Pink/Orange. Rescue arrows are mandatory in Yellow on IAF aircraft.

During the years of service, some aircraft had their stencils changed from Gunship grey to Black and from Pink/Orange to Red. On other occasions, they were painted in the original colors. Check your photos to choose the correct stencils.

In recent years, Hebrew Walkway / No Step has replaced the traditional English ones.

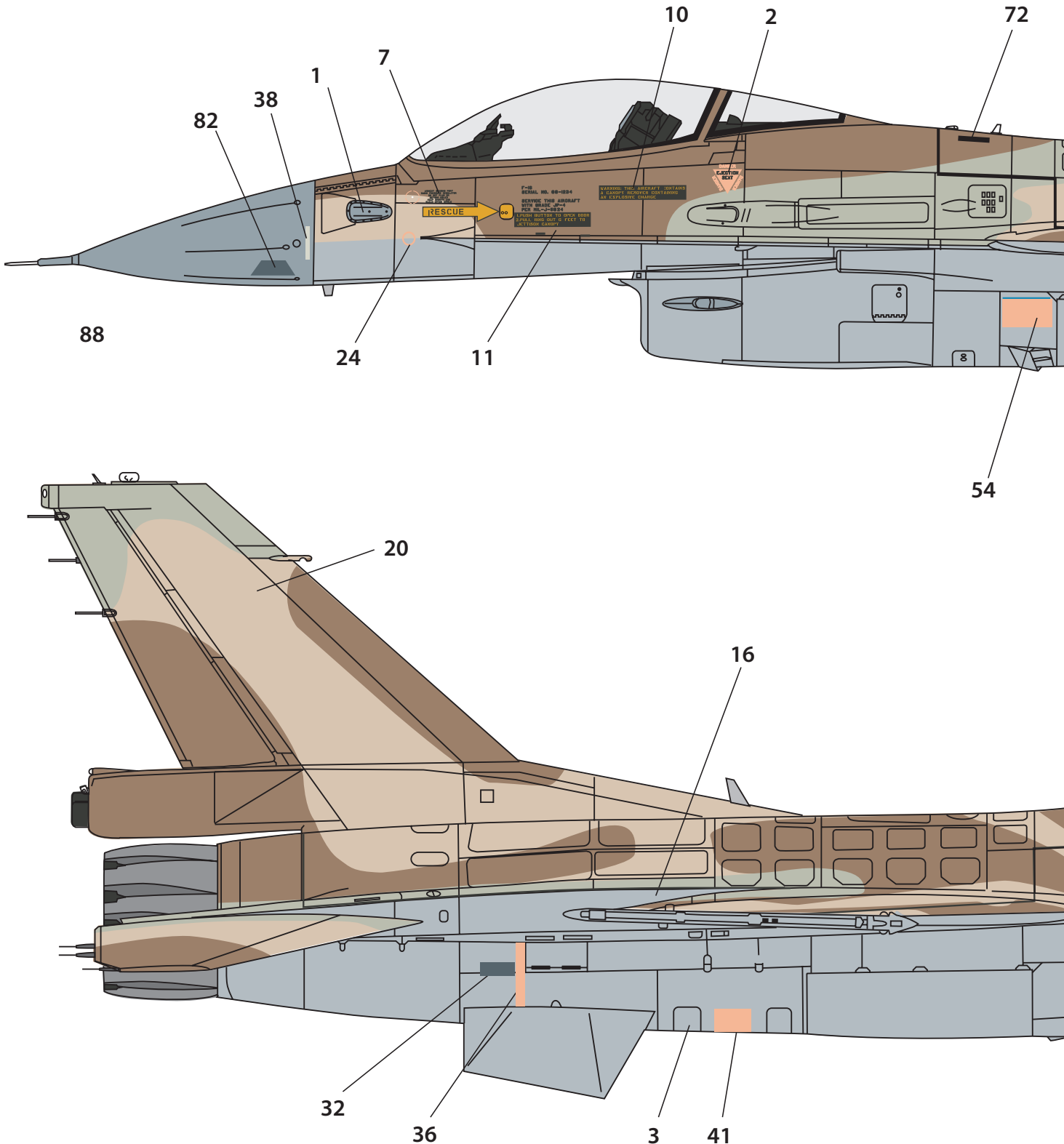

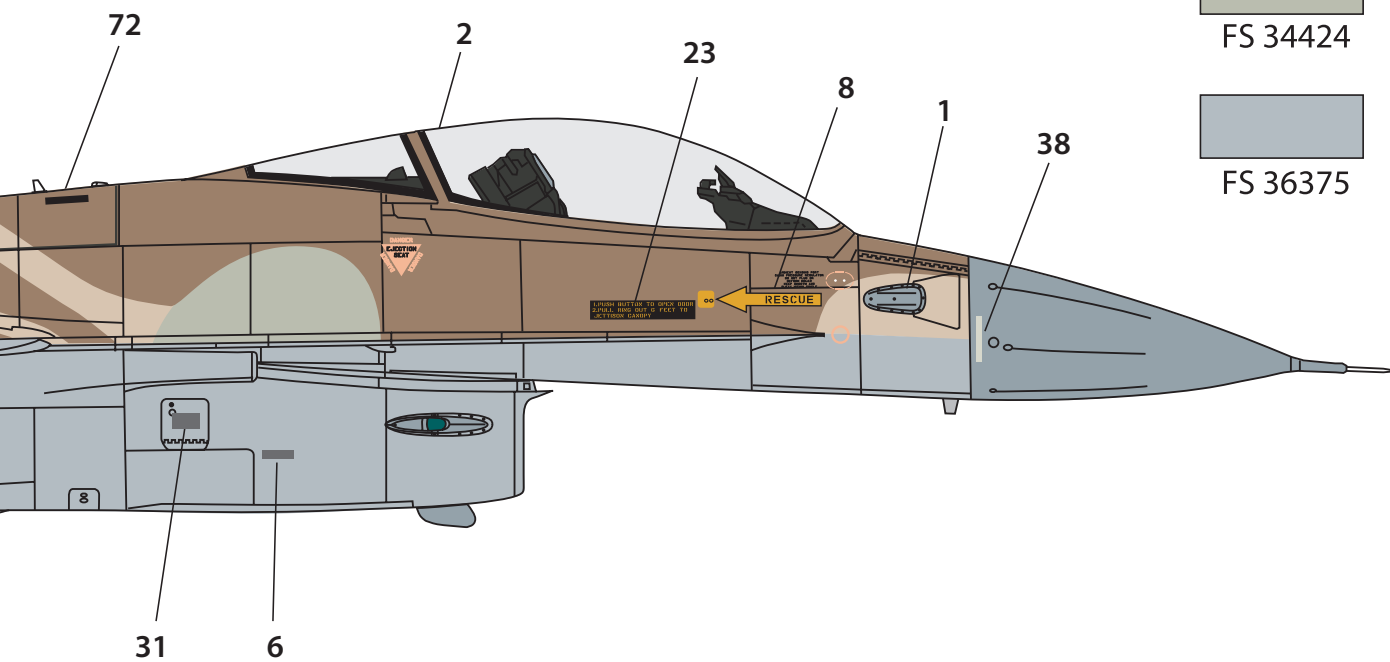
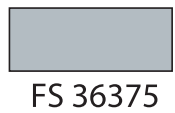
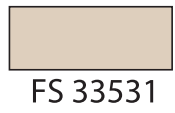
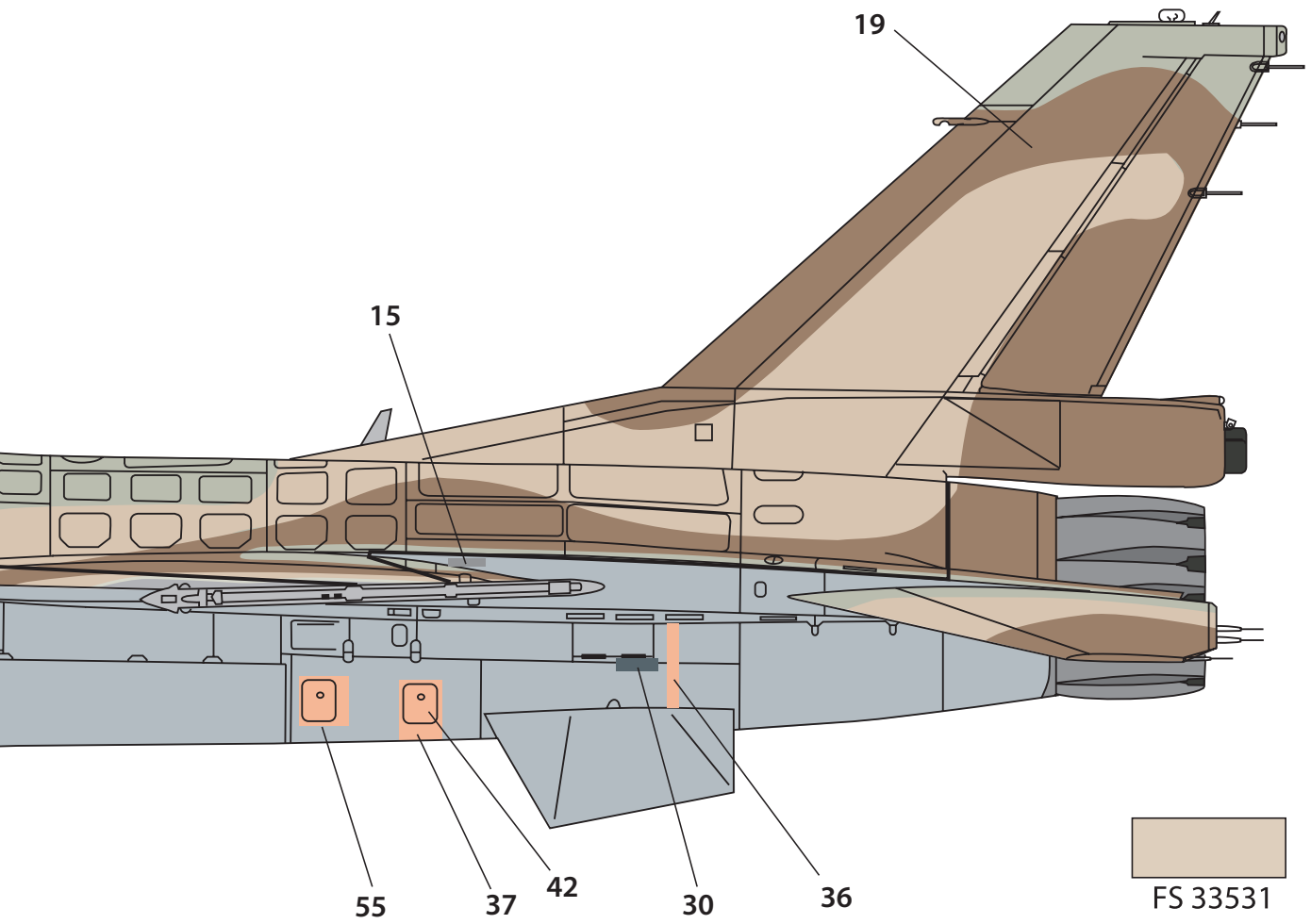

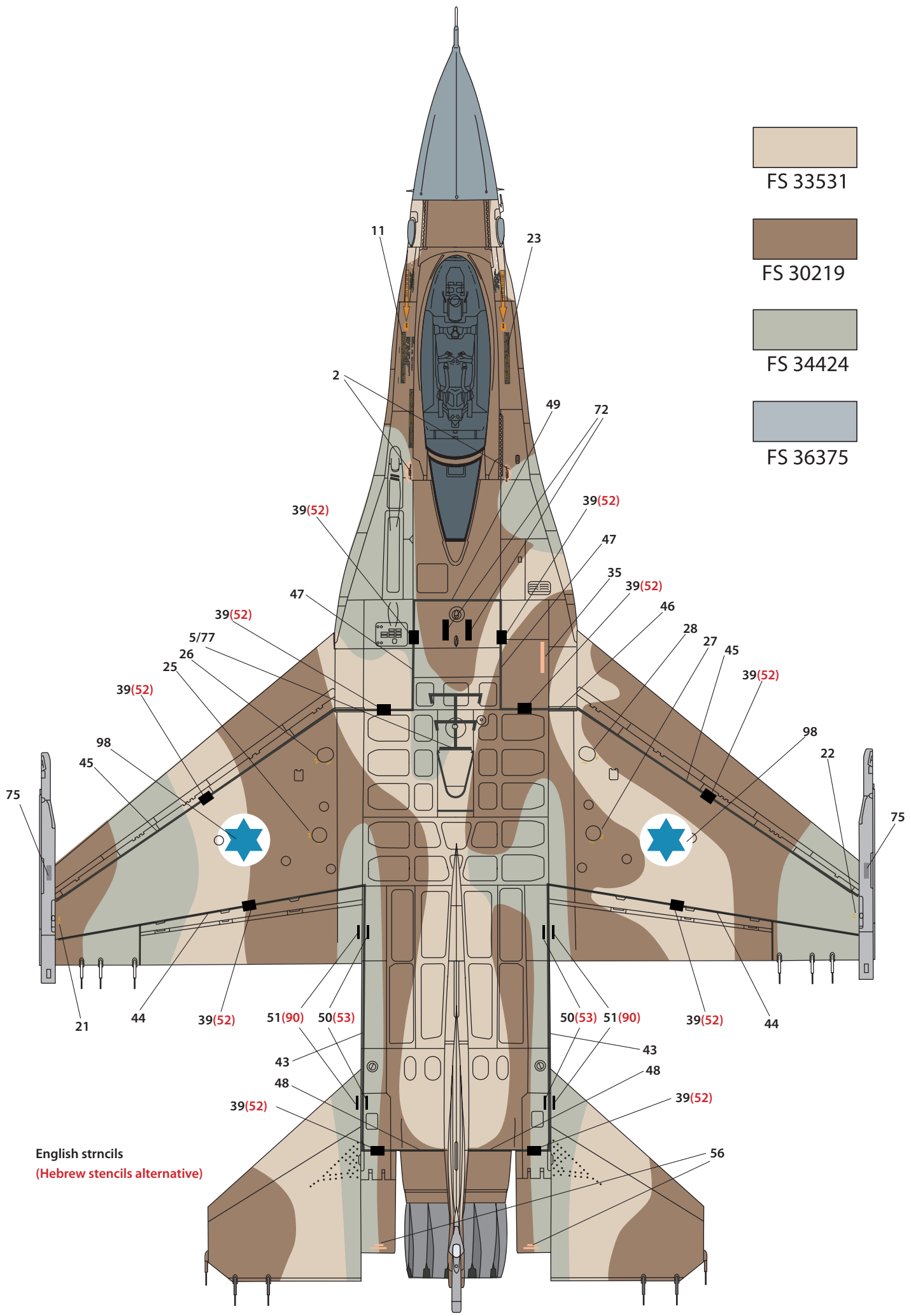

FS 33531



FS 30219



FS 34424



FS 36375

English strncils  
(Hebrew strncils alternative)

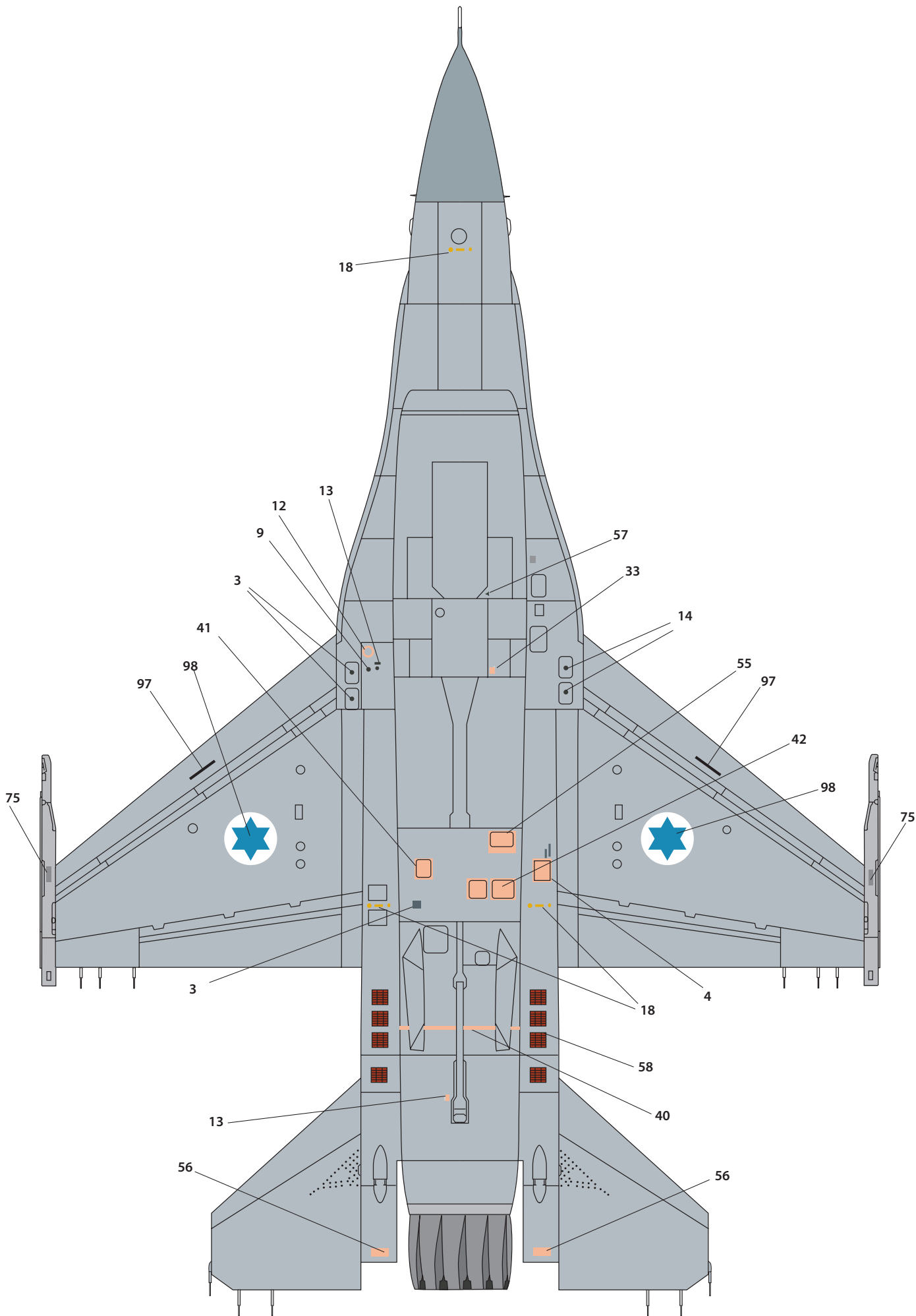

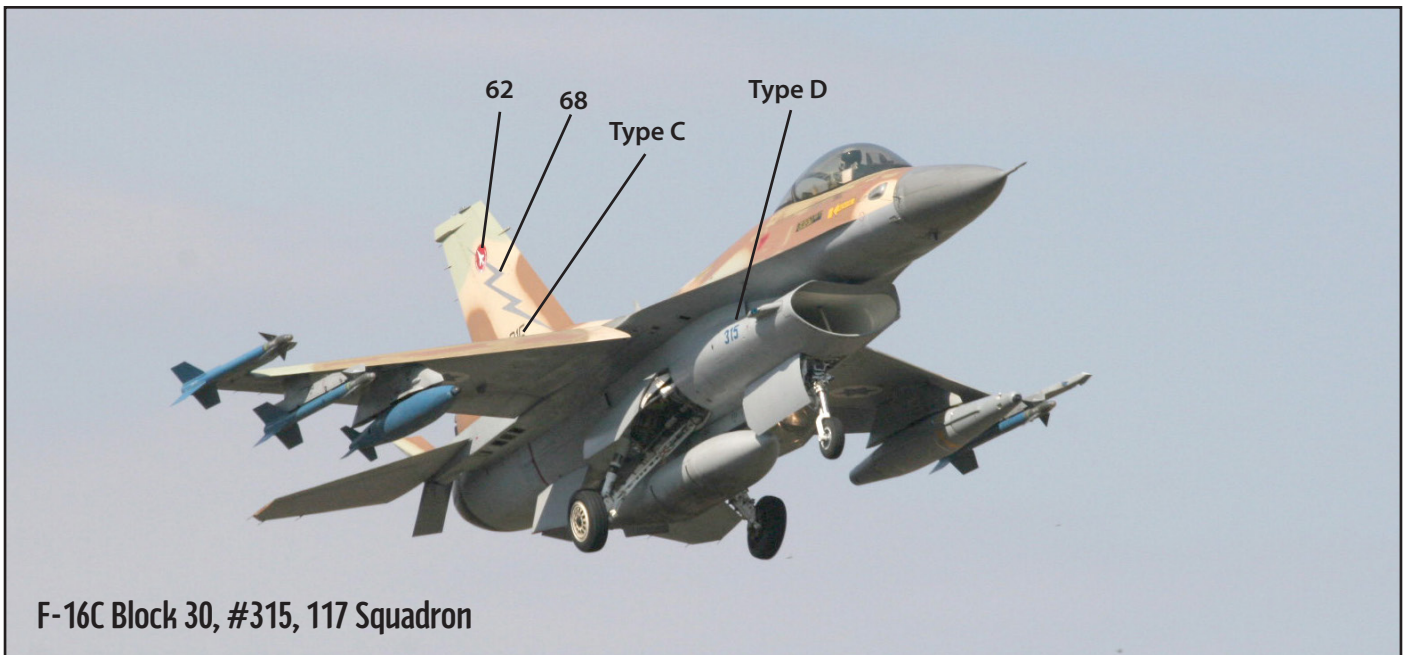
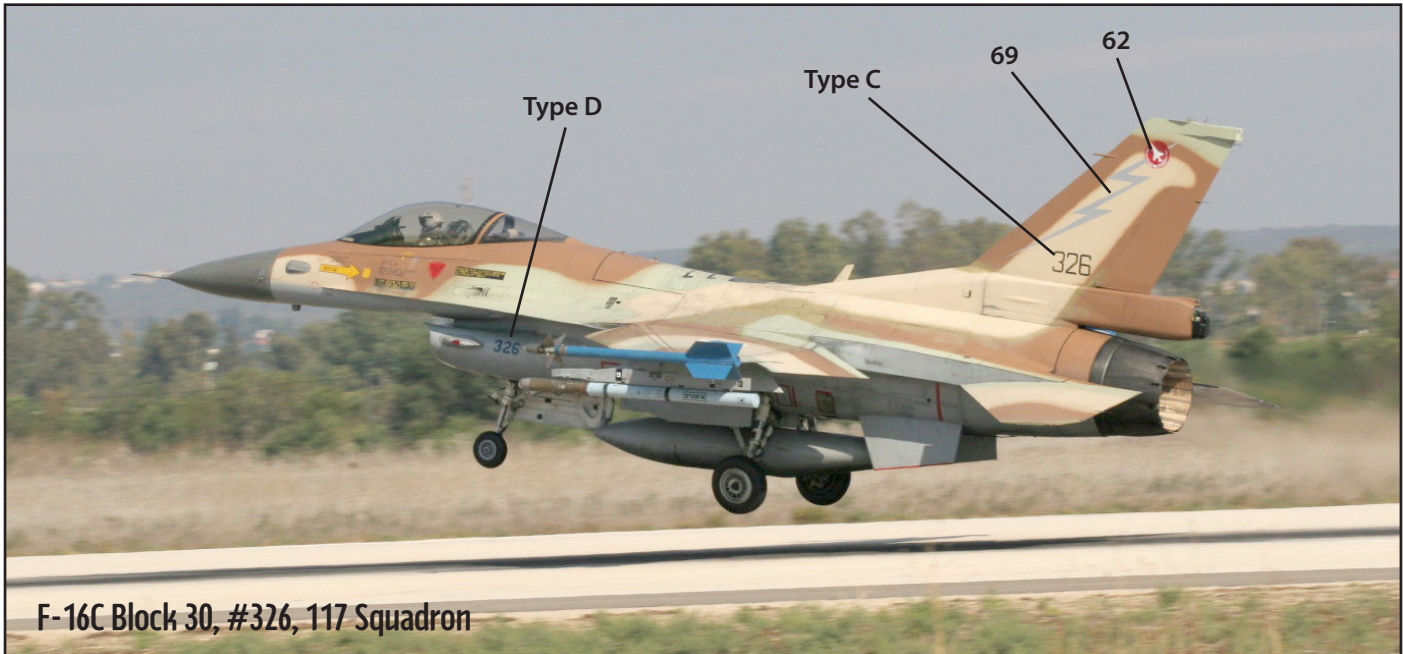
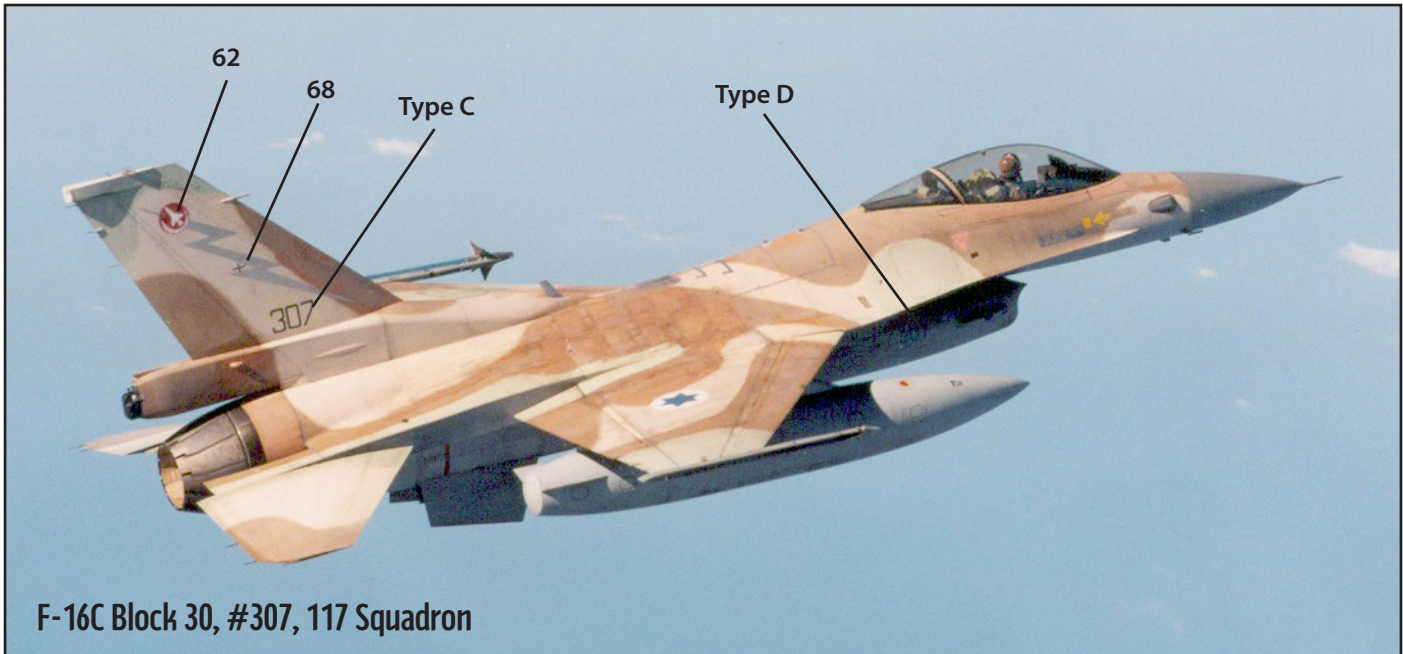

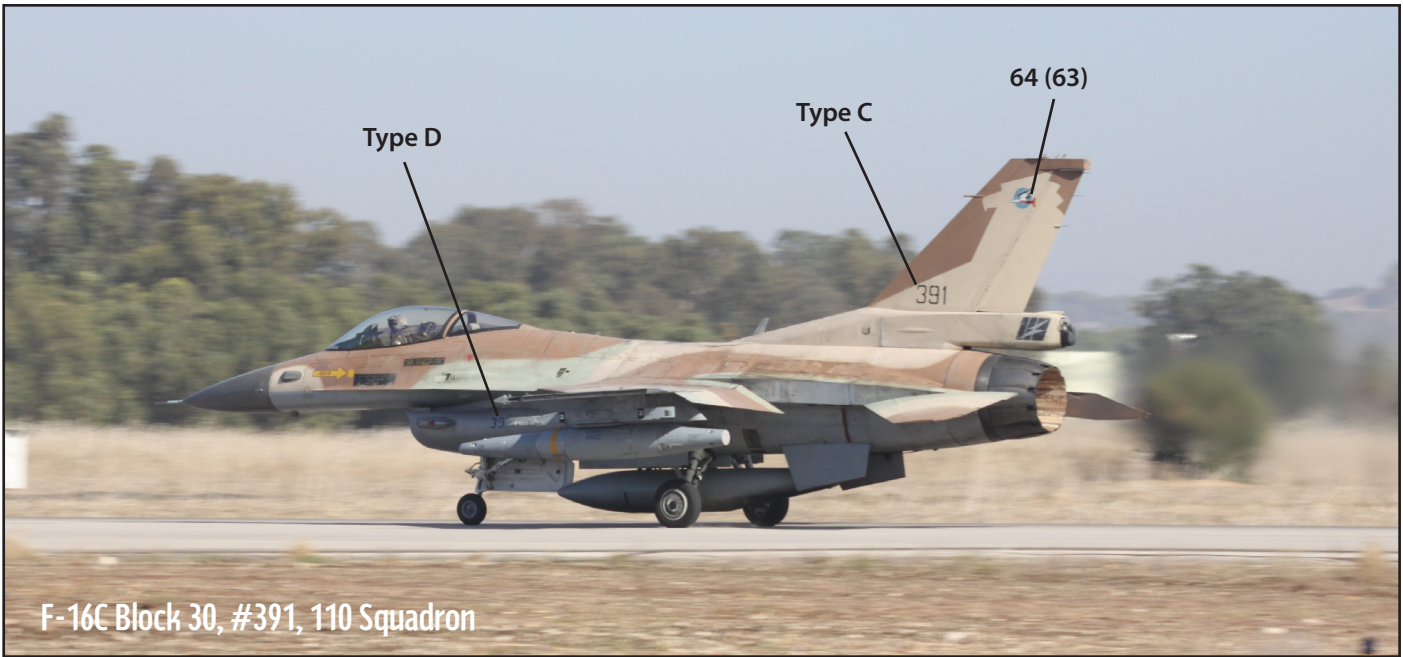
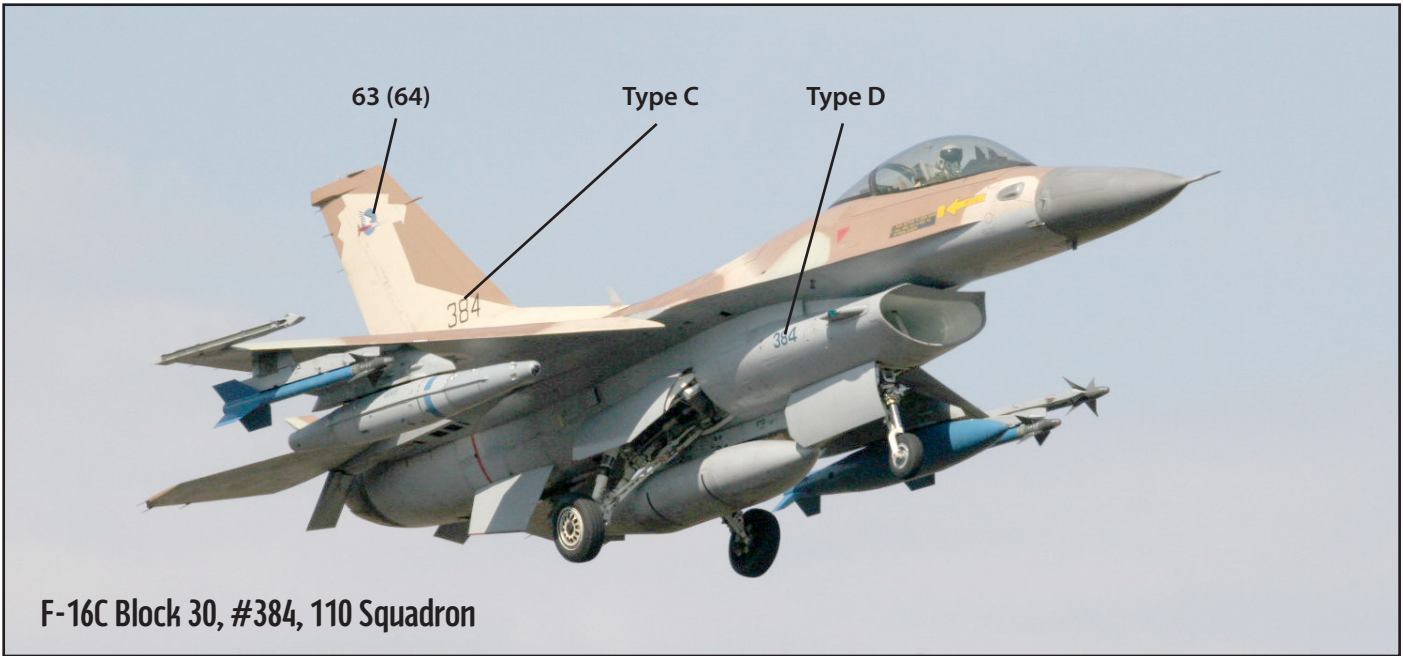
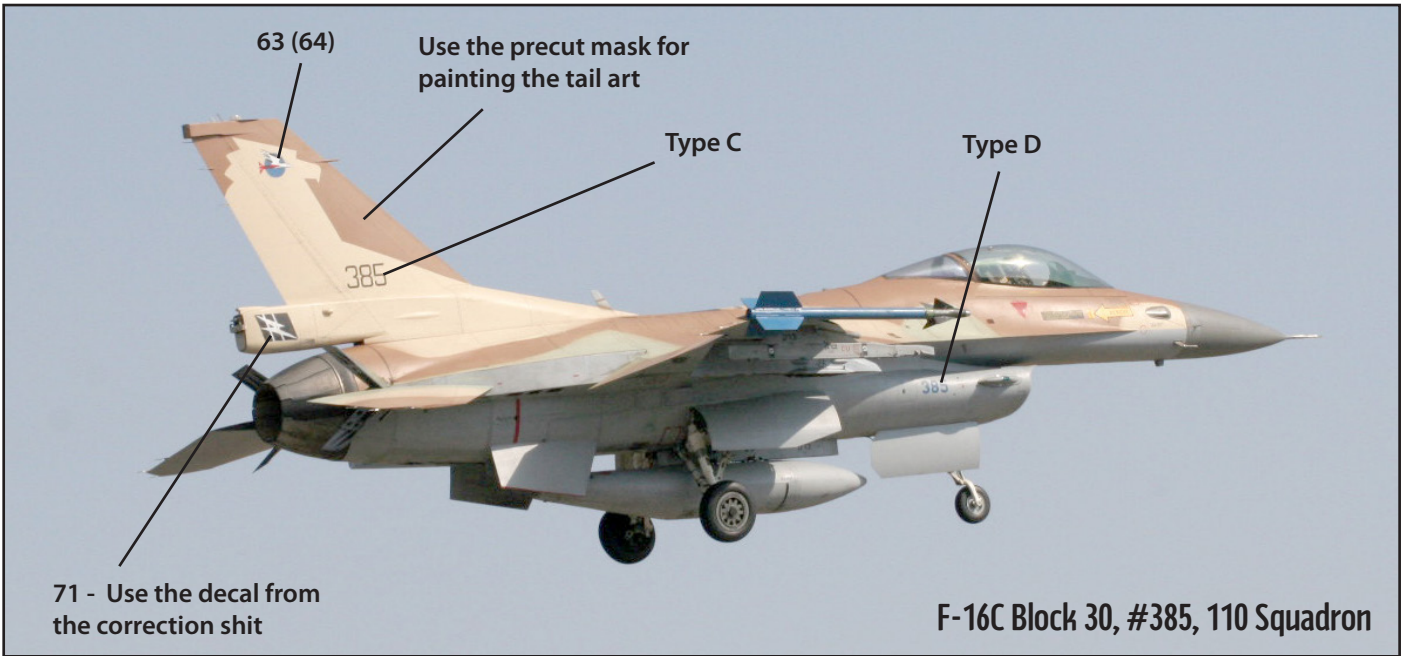

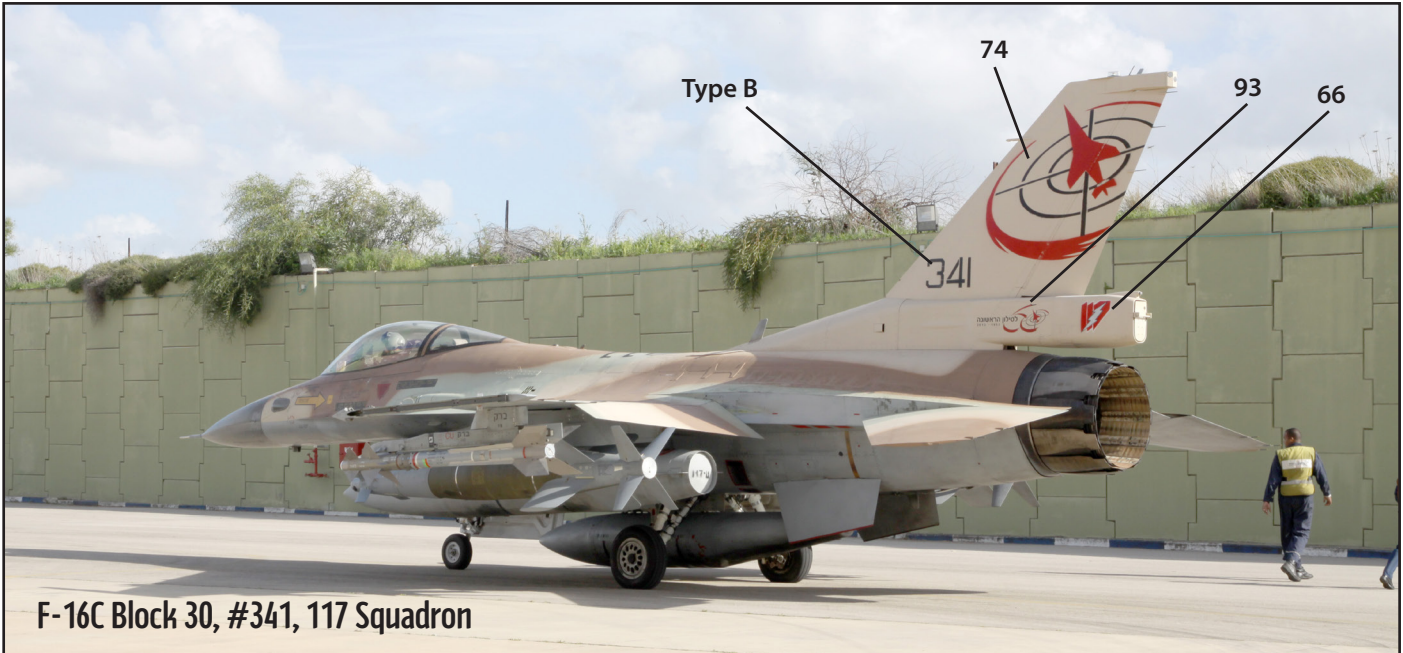

F-16C Block 30, #341, 117 Squadron

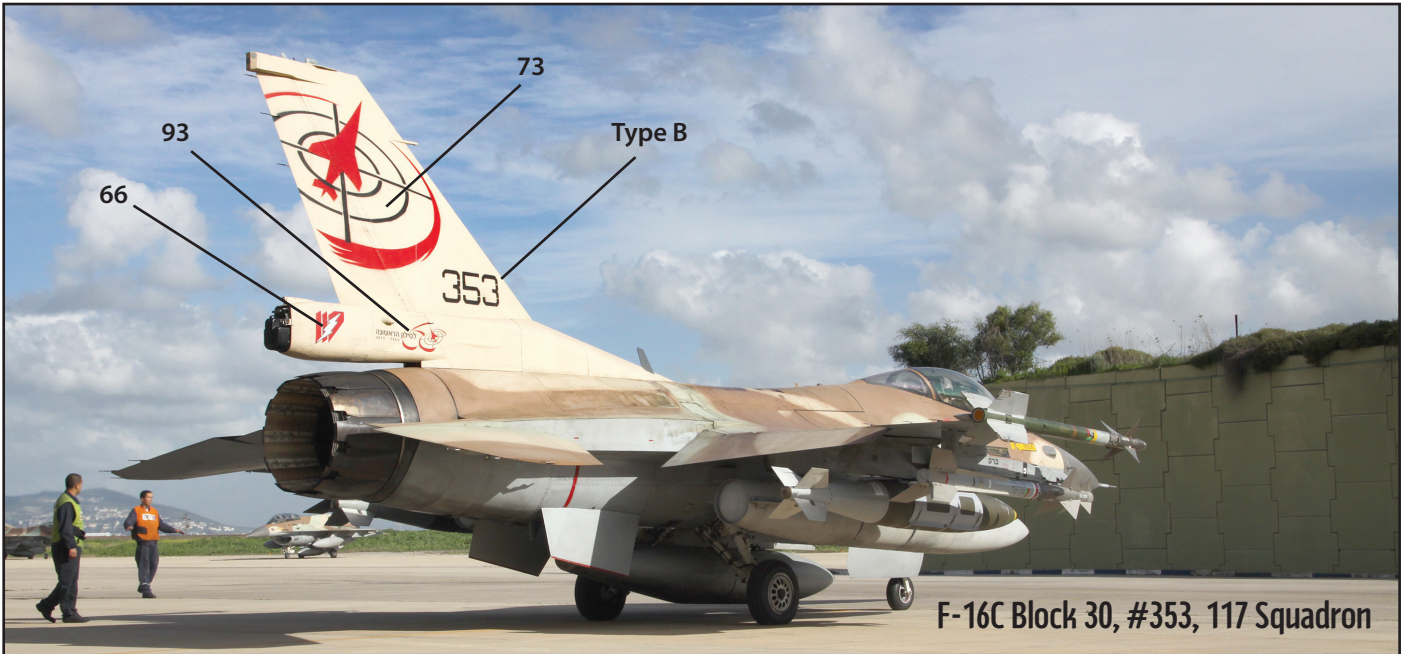

F-16C Block 30, #353, 117 Squadron

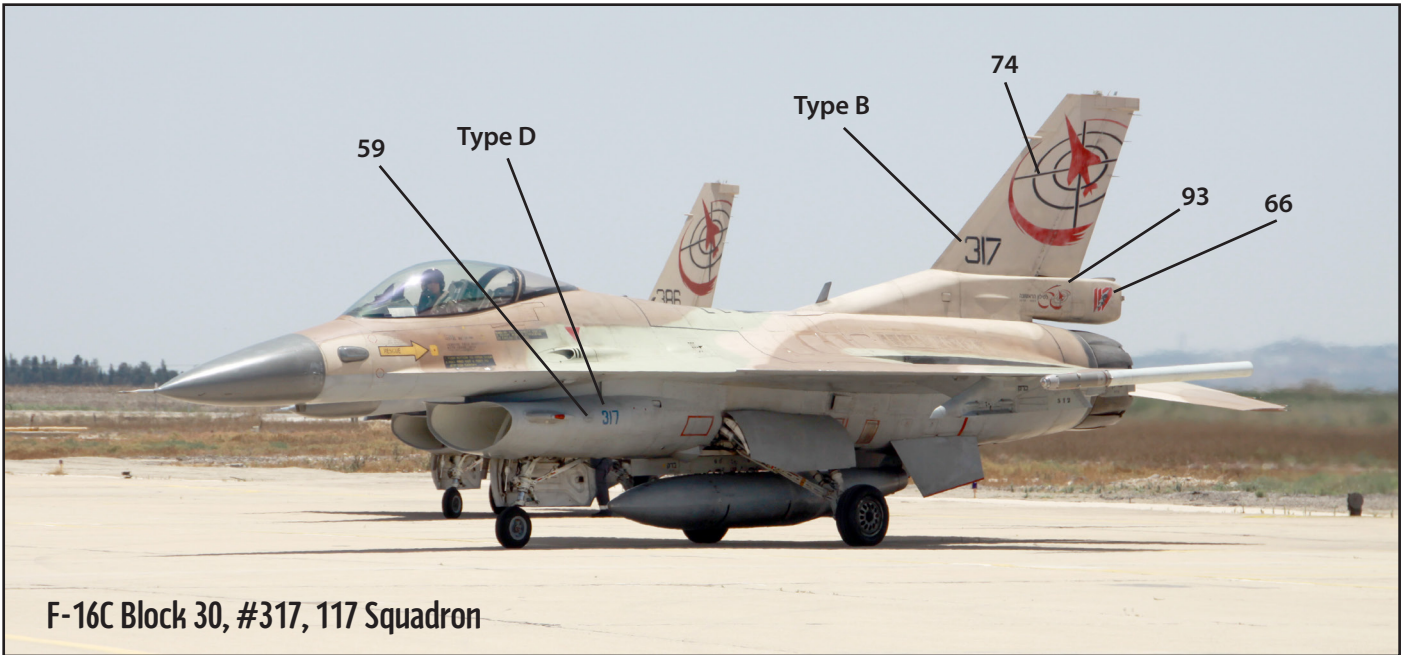

F-16C Block 30, #317, 117 Squadron



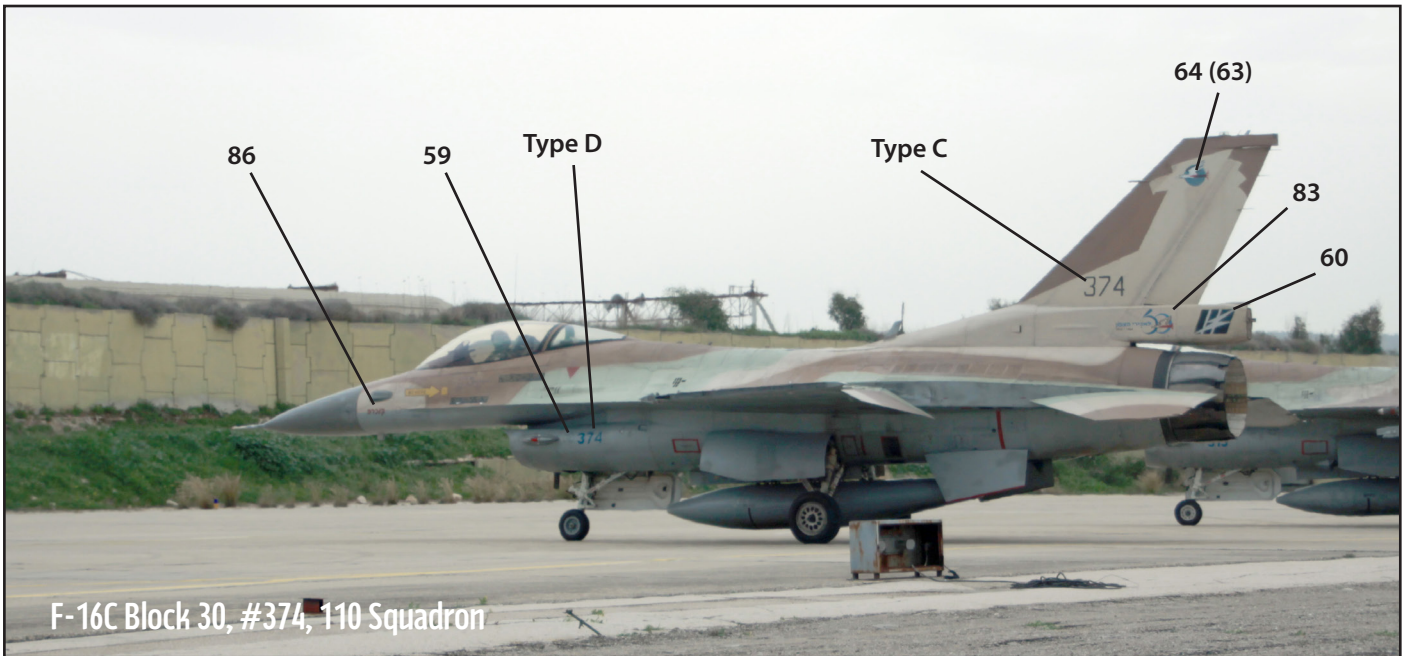



The set provides six names given to six different aircraft of the 110 squadron.

The names were painted on the aircraft nose only on the left side.

- Jaguar-Decal #89-a/c #376
- Big Brother - Decal #392-a/c #392
- David - Decal #84 - a/c #313
- Dragon - Decal #87 - a/c #377
- Cobra - Decal #86 - a/c #374
- The Panther - Decal #88 - a/c #364

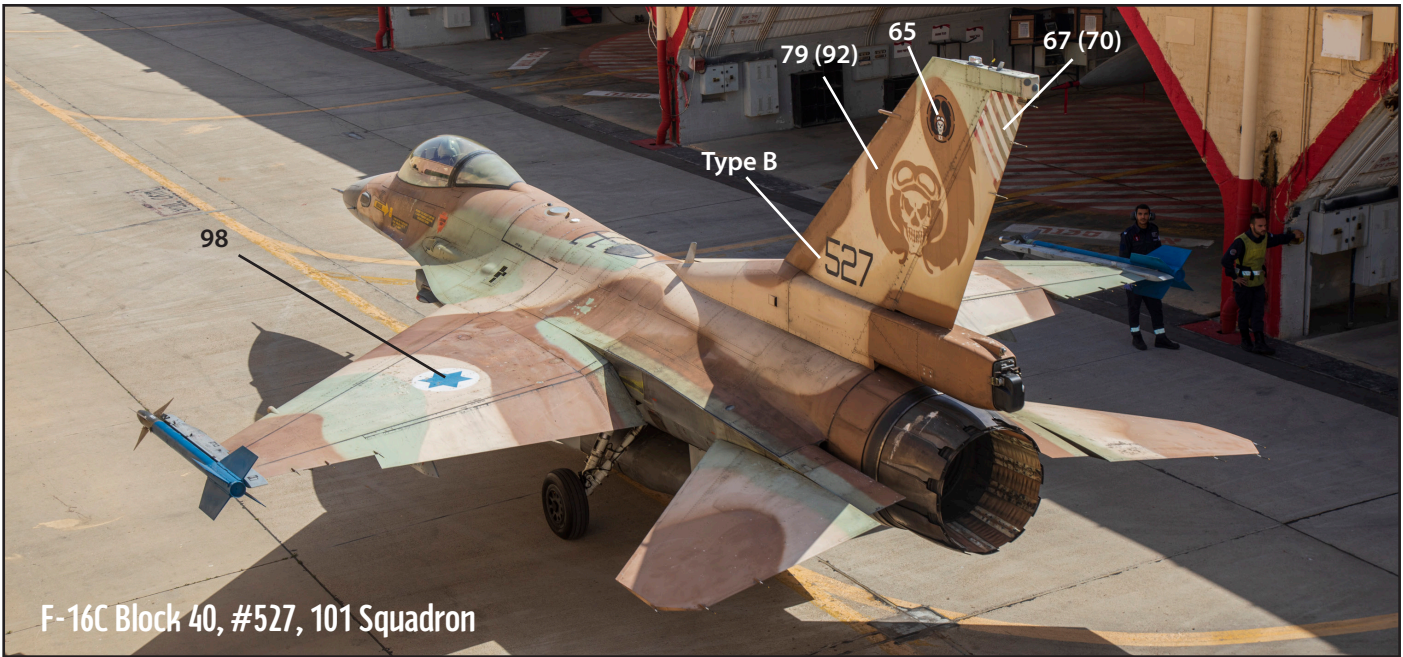

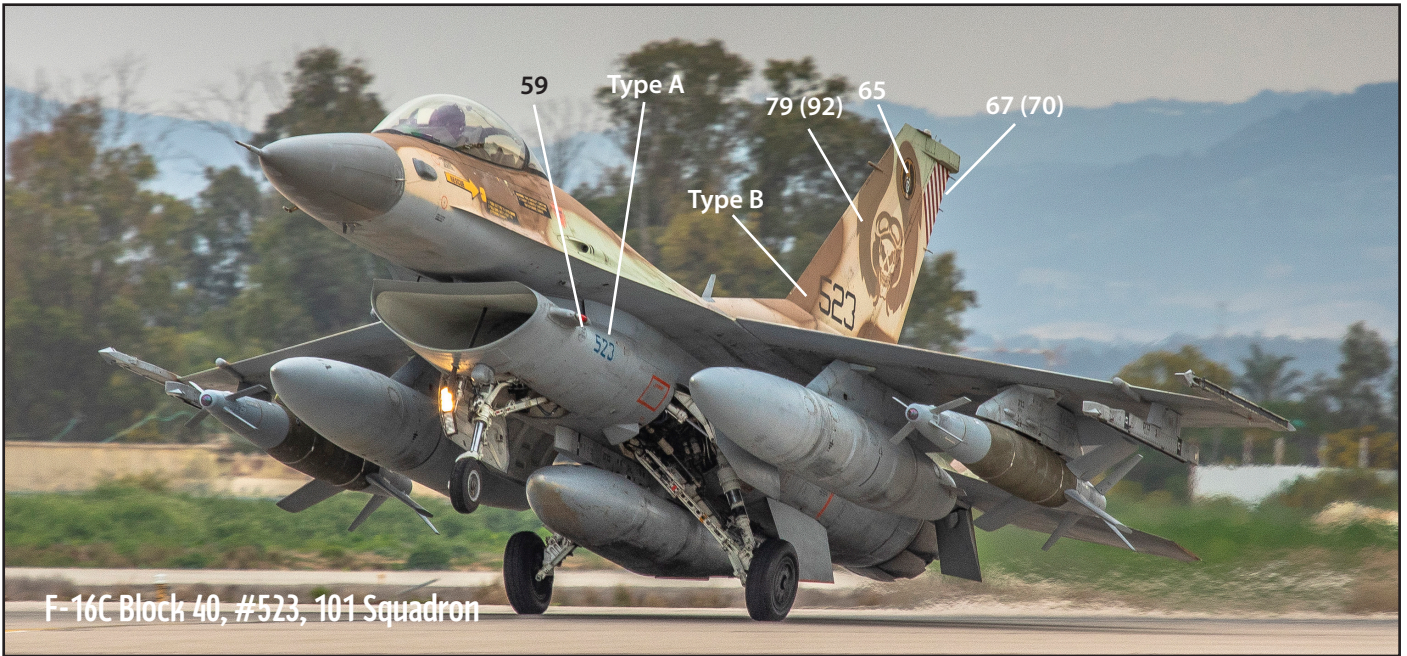

Shay Finkelman ©

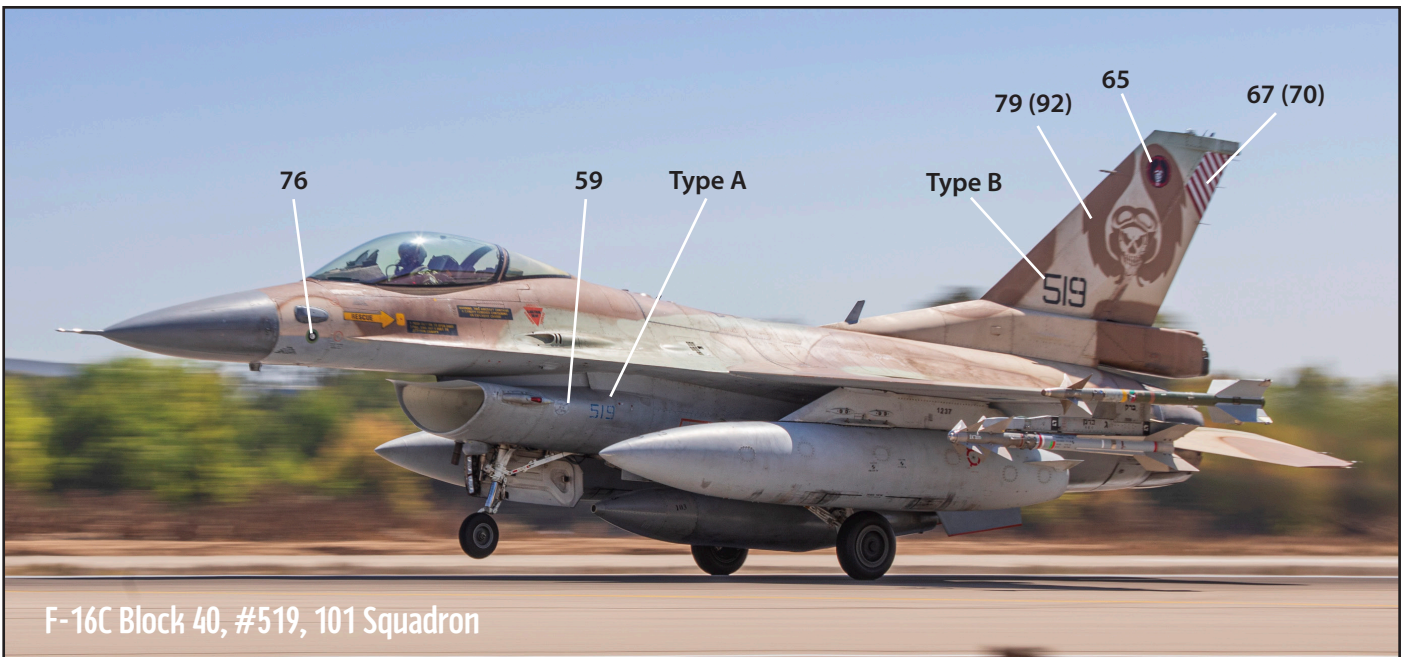

Shay Finkelman ©

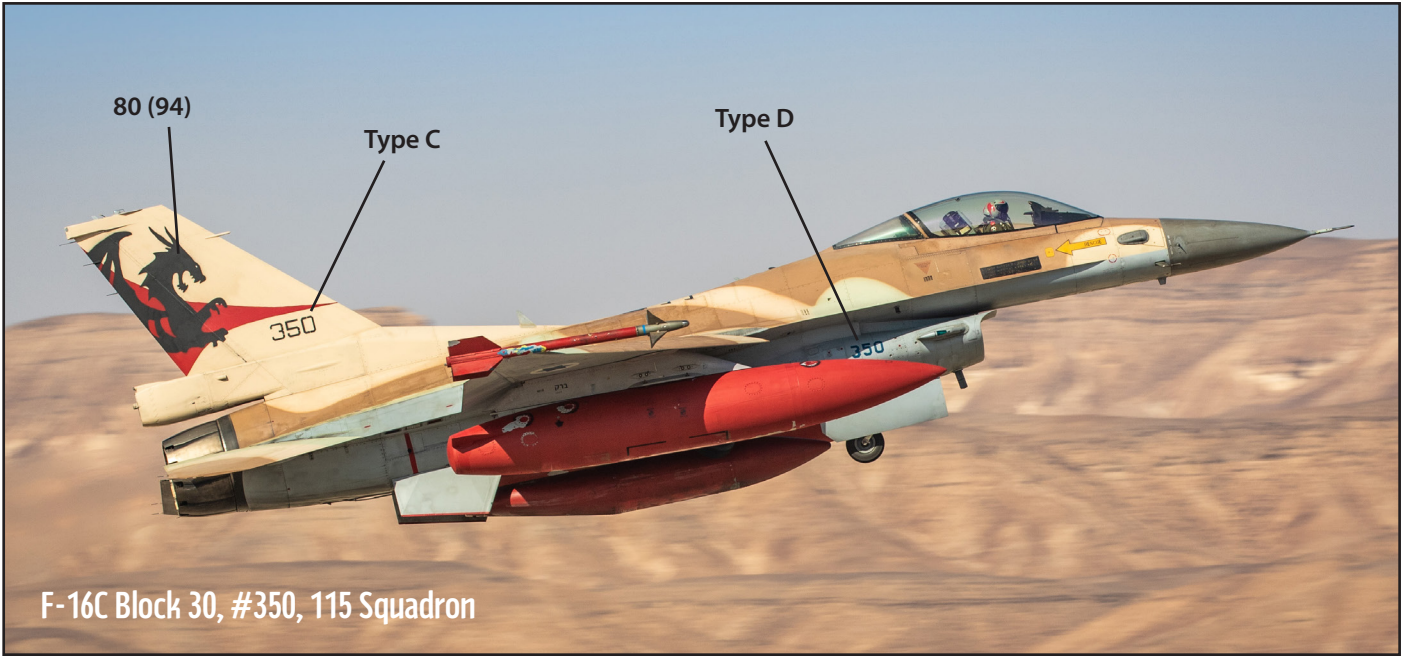

F-16C Block 30, #350, 115 Squadron



F-16C Block 30, #344, 115 Squadron

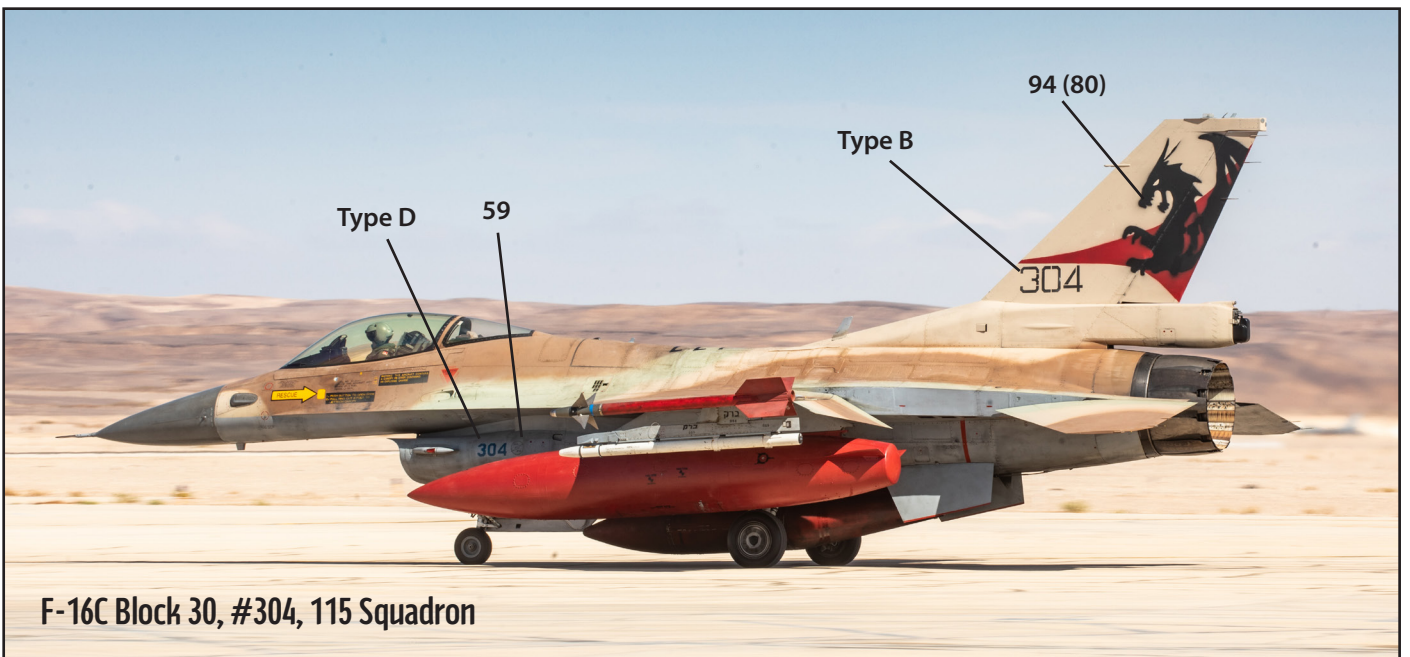

F-16C Block 30, #304, 115 Squadron

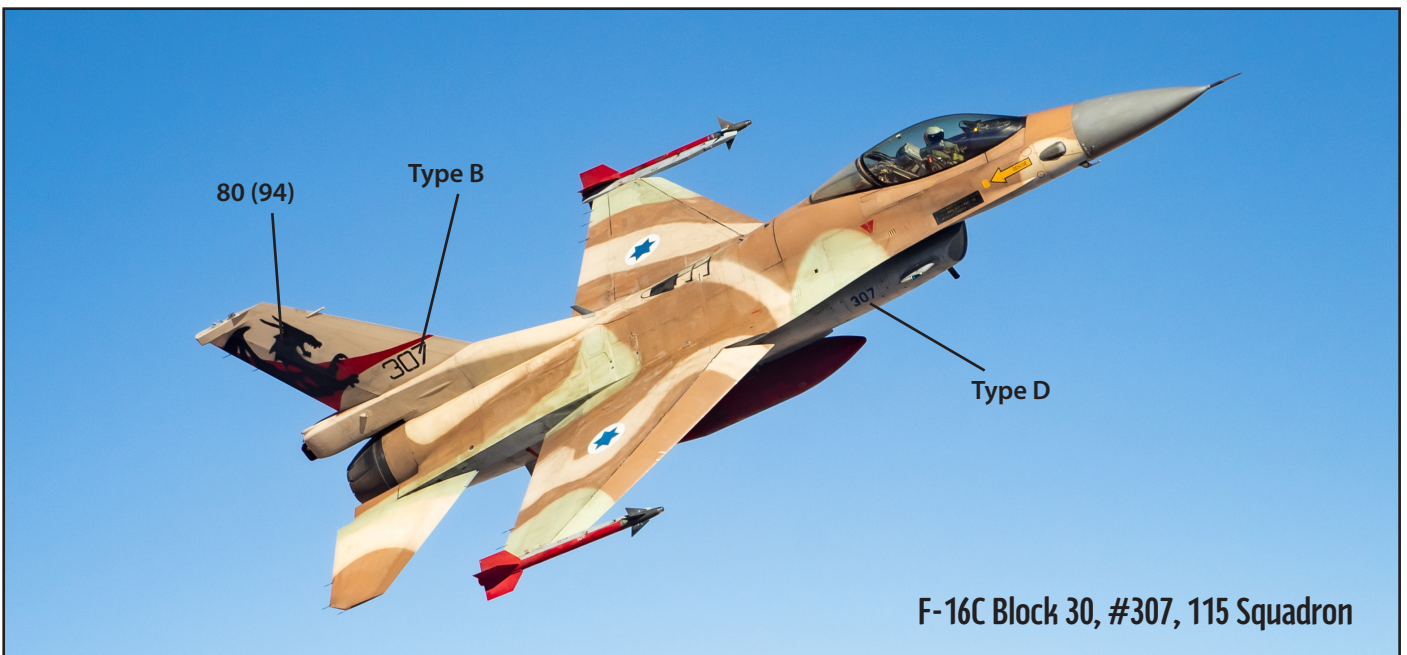
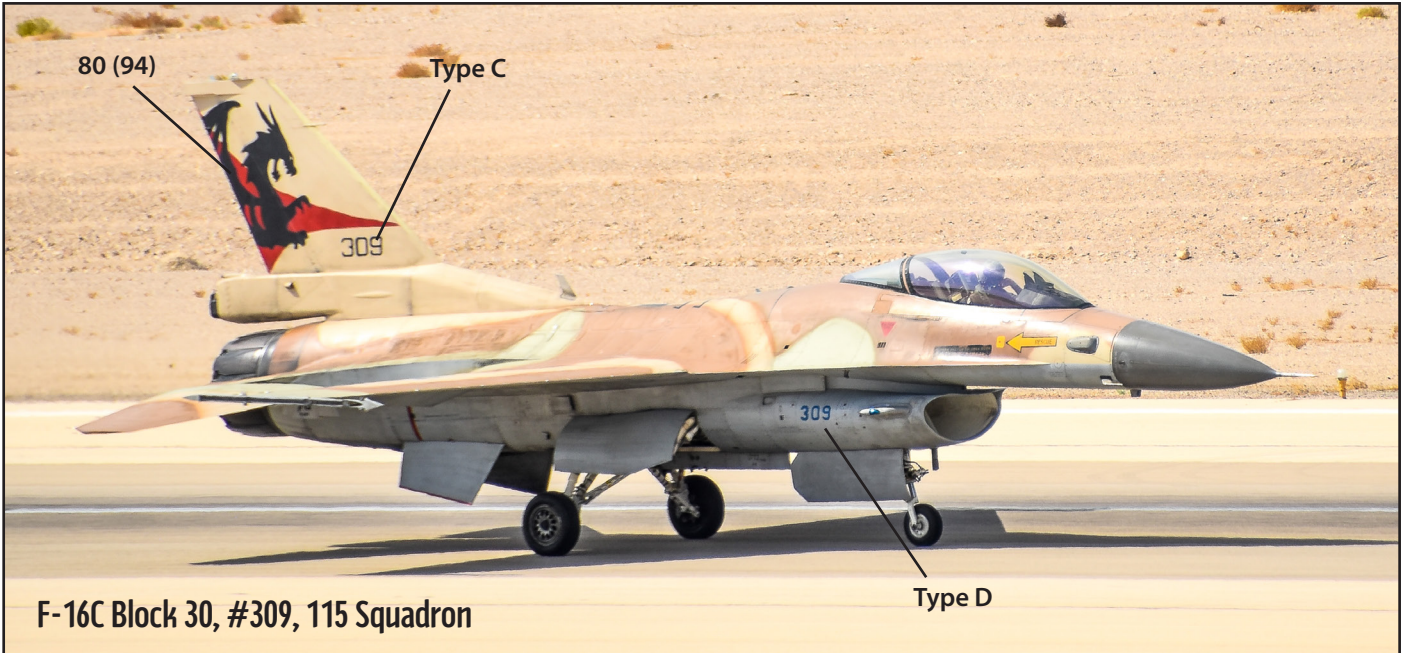

Suggested references

## F-16C/D Barak in IAF service

132 pages

Publication #8. Series 'Aircraft in Detail'.

Over 750 photos!



Photo: Amit Agronov - IAF Magazine ©

[www.isradecal.com](http://www.isradecal.com)

[isradecal@gmail.com](mailto:isradecal@gmail.com)

**IsraDecal**   
PUBLICATIONS